

इंटरनेट

मानक

### Disclosure to Promote the Right To Information

Whereas the Parliament of India has set out to provide a practical regime of right to information for citizens to secure access to information under the control of public authorities, in order to promote transparency and accountability in the working of every public authority, and whereas the attached publication of the Bureau of Indian Standards is of particular interest to the public, particularly disadvantaged communities and those engaged in the pursuit of education and knowledge, the attached public safety standard is made available to promote the timely dissemination of this information in an accurate manner to the public.

“जानने का अधिकार, जीने का अधिकार”

Mazdoor Kisan Shakti Sangathan

“The Right to Information, The Right to Live”

“पुराने को छोड़ नये के तरफ”

Jawaharlal Nehru

“Step Out From the Old to the New”

IS 9527-3 (1983): Code of practice for design and construction of port and harbour structures, Part 3: Sheet pile walls [CED 47: Ports and Harbours]



“ज्ञान से एक नये भारत का निर्माण”

Satyanarayan Gangaram Pitroda

“Invent a New India Using Knowledge”



“ज्ञान एक ऐसा खजाना है जो कभी चुराया नहीं जा सकता है”

Bhartrhari—Nitiśatakam

“Knowledge is such a treasure which cannot be stolen”



BLANK PAGE



IS : 9527 ( Part III ) - 1983

*Indian Standard*

CODE OF PRACTICE FOR  
DESIGN AND CONSTRUCTION OF  
PORT AND HARBOUR STRUCTURES

**PART III SHEET PILE WALLS**

( First Reprint AUGUST 1997 )

UDC 627.21 : 624.04 : 624.154-405.8 : 69.022 : 006.76

© *Copyright* 1983

**BUREAU OF INDIAN STANDARDS**  
MANAK BHAVAN, 9 BAHADUR SHAH ZAFAR MARG  
NEW DELHI 110002

# Indian Standard

## CODE OF PRACTICE FOR DESIGN AND CONSTRUCTION OF PORT AND HARBOUR STRUCTURES

### PART III SHEET PILE WALLS

Ports and Harbours Sectional Committee, BDC 66

<i>Chairman</i>	<i>Representing</i>
SHRI H. R. LAXMINARAYAN	Ministry of Shipping and Transport
<i>Members</i>	
Shri T. R. SUBRAMANYAM ( <i>Alternate to</i> Shri H. R. Laxminarayan )	Mormugao Port Trust, Vasco-Da-Gama
SHRI M. BALASUBRAMANIAM	Pre-Investment Survey of Fishing Harbour,
SHRI N. P. BHAKTA	Bangalore
SHRI H. V. RAMASWAMY ( <i>Alternate</i> )	
DR A. N. BISWAS	Hydraulic Study Department, Calcutta Port Trust, Calcutta
DR K. K. BANDYOPADHYAY ( <i>Alternate</i> )	
BRIG K. P. CHANDRASEKHARAN	Engineering Department, Madras Port Trust, Madras
SHRI T. V. RANGANATHAN ( <i>Alternate</i> )	
CHIEF ENGINEER	Chief Engineer's Department, Calcutta Port Trust, Calcutta
CHIEF PORTS OFFICER	Maharashtra State Port Authority, Bombay
COASTAL ENGINEER ( <i>Alternate</i> )	
DIRECTOR	Central Water and Power Research Station, Pune
CHIEF RESEARCH OFFICER I ( <i>Alternate</i> )	
SHRI A. H. DIVANJI	Asia Foundation & Construction Pvt Ltd, Bombay
SHRI A. N. JANGLE ( <i>Alternate</i> )	
CAPT D. K. DUTTA	Marine Department, Calcutta Port Trust, Calcutta
CAPT S. SEN ( <i>Alternate</i> )	
SHRI K. K. FRAMJI	Consulting Engineering Services India Pvt Ltd, New Delhi
SHRI S. GHOSH ( <i>Alternate</i> )	

( Continued on page 2 )

© Copyright 1983

BUREAU OF INDIAN STANDARDS

This publication is protected under the *Indian Copyright Act* ( XIV of 1957 ) and reproduction in whole or in part by any means except with written permission of the publisher shall be deemed to be an infringement of copyright under the said Act.

( Continued from page 1 )

<i>Members</i>	<i>Representing</i>
SHRI M. GNANAOLIVU	Andaman Lakshadweep Harbour Works, New Delhi
SHRI A. V. RANADE ( <i>Alternate</i> )	
SHRI S. GOPALAN EXECUTIVE ENGINEER ( DESIGNS ) ( <i>Alternate</i> )	Tuticorin Port Trust, Tuticorin
SHRI HASMUKH P. OZA	In personal capacity ( <i>Atul, 20 Pathik Society, Ahmadabad</i> )
CAPT R. D. KOHLI	Shipping Corporation of India, Bombay
SHRI B. P. KUKADIA	Gujarat Maritime Board, Ahmadabad
CAPT ABRAHAM KURUVILLA	Cochin Port Trust, Cochin
CAPT VARGHESE KURUVILLA ( <i>Alternate</i> )	
CAPT G. A. MANDE	Marine Department, Madras Port Trust, Madras
CAPT V. K. KAPUR ( <i>Alternate</i> )	
SHRI H. NANDI	Continental Construction Pvt Ltd, New Delhi
PROF S. NARASIMHAN	Indian Institute of Technology, Bombay
DR I. V. NAYAK	Karnataka Regional Engineering College, Srinivasnagar
PROF G. RANGANNA ( <i>Alternate</i> )	
BRIG OMBIR SINGH	Engineer-in-Chief's Branch, Army Headquarters. New Delhi
BRIG GURCHARAN SINGH ( <i>Alternate</i> )	
SHRI B. K. PANTHAKY	Hindustan Construction Co Ltd, Bombay
SHRI P. V. NAIK ( <i>Alternate</i> )	
SHRI T. V. RAMANA RAO	Visakhapatnam Port Trust, Visakhapatnam
REPRESENTATIVE	Oil and Natural Gas Commission, Dehra Dun
SHRI S. R. ROESSLER	Howe ( India ) Pvt Ltd, New Delhi
SHRI C. S. DEBKE ( <i>Alternate</i> )	
REAR-ADMIRAL S. B. N. SINGH	Indian Navy ( Ministry of Defence ), Visakhapatnam
LT-COL S. S. GILL ( <i>Alternate</i> )	
SUPERINTENDING ENGINEER ( CENTRAL MECHANICAL CIRCLE )	Public Works Department, Government of Tamil Nadu, Madras
SENIOR DEPUTY CHIEF ENGINEER ( BUILDINGS ) ( <i>Alternate</i> )	
CAPT R. B. SURI	Indian Navy ( Operational ), Ministry of Defence
CDR T. L. RATTAN ( <i>Alternate</i> )	
SHRI M. C. TANDON	Stup Consultants Ltd, Bombay
SHRI M. K. CHATTERJEE ( <i>Alternate</i> )	
DR V. D. TAPASVI	Engineers India Ltd, New Delhi
SHRI M. CHOWDHURY ( <i>Alternate</i> )	
SHRI R. V. TIPNIS	Bombay Port Trust, Bombay
SHRI G. RAMAN, Director ( Civ Engg )	Director General, BIS ( <i>Ex-officio Member</i> )

*Secretary*

SHRI M. N. NEELAKANDHAN  
Deputy Director ( Civ Engg ), BIS

# *Indian Standard*

## CODE OF PRACTICE FOR DESIGN AND CONSTRUCTION OF PORT AND HARBOUR STRUCTURES

### PART III SHEET PILE WALLS

#### 0. FOREWORD

**0.1** This Indian Standard ( Part III ) was adopted by the Indian Standards Institution on 28 January 1983, after the draft finalized by the Ports and Harbours Sectional Committee had been approved by the Civil Engineering Division Council.

**0.2** In order to assist the design and construction engineers in the field of ports and harbours, the Committee has initiated formulation of Indian Standards covering various aspects of design and construction of ports and harbours. This standard is being prepared in following parts:

- Part I Concrete monoliths
- Part II Caissons
- Part III Sheet pile walls
- Part IV Cellular sheet pile structures

The first and fourth parts of the standard have already been issued as IS : 9527 ( Part I )-1981\* and IS : 9527 ( Part IV )-1980† respectively.

**0.3** This code deals with the criteria for design and construction of sheet pile walls used in port and harbour construction. Sheet pile walls comprise of a row of piles engaging with or interlocking with one another so as to form a continuous wall to be used as a permanent or temporary earth retaining structure.

**0.4** While preparing this standard ( Part III ), the provisions relating to sheet pile retaining walls earlier covered in ' IS : 4651 ( Part IV )-1969 Code of practice for design and construction of dock and harbour structures : Part IV Sheet pile retaining walls have been taken into consideration. IS : 4651 ( Part IV )-1969 has subsequently been revised

---

\*Code of practice for design and construction of port and harbour structures : Part I Concrete monolith.

†Code of practice for design and construction of port and harbour structures : Part IV Cellular sheet pile structures.

with a change in the scope of this standard and issued as IS : 4651 ( Part IV )-1979 Code of practice for planning and design of ports and harbours : Part IV General design considerations.

**0.5** In the formulation of this standard due weightage has been given to international coordination among the standards and practices prevailing in different countries in addition to relating it to the practices in the field in this country.

**0.6** For the purpose of deciding whether a particular requirement of this standard is complied with, the final value, observed or calculated, expressing the result of a test or analysis, shall be rounded off in accordance with IS : 2-1960\*. The number of significant places retained in the rounded off value should be the same as that of the specified value in this standard.

---

## 1. SCOPE

**1.1** This standard ( Part III ) deals with criteria for design and construction of sheet pile walls with particular reference to port and harbour structures.

NOTE — For recommendations on design and construction of diaphragm walls, IS : 9556-1980† may be referred to.

## 2. TERMINOLOGY

**2.0** For the purpose of this standard the definitions as given in IS : 2809-1972‡, IS : 7314-1974§ and the following shall apply.

**2.1 Deadman** — Deadman is a concrete block or a continuous concrete beam used as an anchorage. It derives its resistance primarily from passive earth pressure.

**2.2 Tie** — Tie is a structural member used to transfer load from walls to the anchorage; it may be a bar of structural steel with round or square cross-section or a group of high tensile wires or strands, fully stressed or not.

**2.3 Wale** — In the system of anchored sheet piling, a wale is a flexural member placed horizontally either inside or outside the sheet pile wall. Its function is to receive the horizontal reaction from the sheet piling and transfer it to the tie.

---

\*Rules for rounding off numerical values ( revised ).

†Code of practice for design and construction of diaphragm walls.

‡Glossary of terms and symbols relating to soil engineering ( first revision ).

§Glossary of terms relating to port and harbour engineering.

### 3. SYMBOLS

3.1 For the purpose of this standard, the following letter symbols shall have the meaning indicated against each; where other symbols are used, they are explained at the appropriate place:

$A_p$	Anchor pull or force in tie,
$c$	Cohesion,
$D$	Depth of embedment of sheet pile,
$F_s$	Factor of safety,
$H$	Height of the retained earth,
$L$	Horizontal distance of the nearest edge of the anchoring pile/wall from the edge of the sheet pile wall,
$x$	Depth of point of inflexion below dredge level,
$\gamma$	Bulk ( or moist ) unit weight of soil,
$\gamma'$	Submerged ( buoyant ) unit weight of soil,
$\gamma_{sat}$	Saturated unit weight of soil,
$\gamma_w$	Unit weight of water,
$\delta$	Angle of wall friction,
$\phi$	Angle of internal friction.

### 4. MATERIALS

4.1 Sheet piling walls may be of timber, reinforced concrete, prestressed concrete or steel.

4.1.1 The specification for the timber sheet pile shall be in accordance with IS : 2911 ( Part II )-1980\*.

4.1.2 The materials used for reinforced concrete sheet piling wall shall be in accordance with IS : 456-1978†.

4.1.3 The materials used for the prestressed concrete piling shall be in accordance with IS : 1343-1980‡.

4.1.4 The steel sheet pile shall conform to IS : 2314-1963§. The steel shall have 0.2 to 0.35 percent copper to provide corrosion resistance against sea water.

\*Code of practice for design and construction of pile foundations : Part II Timber piles ( *first revision* ).

†Code of practice for plain and reinforced concrete ( *third revision* ).

‡Code of practice for prestressed concrete ( *first revision* ).

§Specification for steel sheet piling sections.

## **5. TYPES**

**5.1 Cantilever Sheet Pile Wall** — These are fixed in the ground by the passive resistance of the soil in front of and behind the lower part of the sheet of the pile. These are generally used for a retained height of up to 5 m. This type of wall is very sensitive to any erosion, overredging in front of sheeting, unforeseen surcharges behind the wall etc.

**5.2 Anchored Walls** — These are supported by ground anchors or ties or struts at or near the top of sheeting and by passive resistance of soil in front of and behind the lower part of the sheeting. If the wall is very high or subjected to heavy surcharge, two rows of ties may be necessary, the main tie being some distance down the wall and the second tie near the top. Walls with a single line of tie are generally used for retained height up to 10 m depending upon the nature of the soil and surcharge.

## **6. SELECTION**

**6.1** For permanent construction, sheet piles of steel, reinforced concrete or prestressed concrete are generally used. Timber sheet piling is advisable only when the soil strata are favourable for driving and required sectional modulus is low. Steel sheet piles are used where piles have to be driven through highly resistant strata. Steel sheet piles are also used for temporary work since it is comparatively easier to extract them and use them several times. The steel sheet piles also get preference to other types where watertightness is essential. The reinforced concrete and prestressed concrete sheet piles are used where it is possible to drive them and where there is no danger of back fill material seeping through the joints.

## **7. LOADS AND FORCES**

**7.1** In the design for sheet pile wall, account shall be taken of the following types of loads and forces:

- a) Active and passive earth pressure,
- b) Lateral earth pressure due to surcharge loads,
- c) Differential water pressure and seepage pressure,
- d) Mooring pull and ship impact,
- e) Wave pressure,
- f) Earthquake force, and
- g) Stresses due to handling and driving.

**7.2** The loads and forces shall be calculated as given in 7.2.1 to 7.2.4.

7.2.1 For calculating the active and passive earth pressures and lateral earth pressure due to surcharge loads, IS : 4651 ( Part II )-1969\* shall be referred to.

### 7.2.2 Differential Water Pressure and Seepage Pressure

7.2.2.1 Where a tidal lag is expected, the differential water pressure shall be calculated in accordance with 5.4 of IS : 4651 ( Part III )-1974†.

7.2.2.2 If the sheet pile penetrates through a pervious soil, the effect of seepage on the distribution of unbalanced water pressure may be taken roughly as a linear variation below the dredge level. This is represented by line *ab* in Fig. 1. If, however, the sheet pile is driven to reach an impervious stratum, thus effectively cutting off seepage, the unbalanced water pressure may have a distribution represented by line *ac* in Fig. 1.

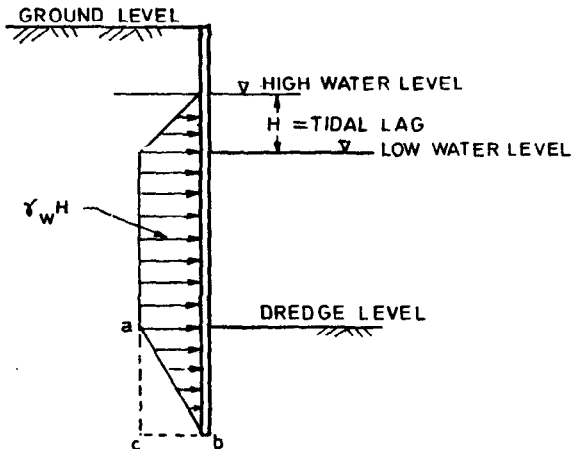

FIG. 1 DISTRIBUTION OF UNBALANCED WATER PRESSURE ON THE BACK OF SHEET PILE WALL

7.2.2.3 The seepage force due to an upward flow of water below the dredge level in front of the bulkhead reduces the vertical effective stress in the soil and thereby reduces the passive earth resistance below

\*Code of practice for planning and design of ports and harbours : Part II Earth pressures.

†Code of practice for planning and design of ports and harbours: Part III Loading (first revision).

the dredge level. The reduction in the submerged unit weight of the soil  $\Delta\gamma'$  may be taken as:

$$\Delta\gamma' = \frac{H}{3D} \gamma_w$$

where

$H$  = tidal lag,

$D$  = pile penetration below the dredge level, and

$\gamma_w$  = unit weight of water.

NOTE — The effect of the downward seepage force on the side of the backfill may be neglected.

**7.2.3** The loads and forces due to mooring pull, ship impact and wave pressure shall be calculated in accordance with IS : 4651 ( Part III )-1974\* and that due to earthquake shall be calculated in accordance with IS : 1893-1975†.

**7.2.4** Dynamic stresses due to driving and handling shall be taken into account.

## 8. DESIGN

### 8.1 Cantilever and Anchored Sheet Pile Walls

**8.1.1 Cantilever Sheet Pile Wall** — Guidelines for the design of cantilever type sheet pile wall are given in Appendix A.

**8.1.2 Anchored Sheet Pile Wall** — Anchored sheet pile walls are designed either using the free earth support method or fixed earth support method. These methods are described in Appendix B and C respectively. The former method may be used when the sheet pile penetrates soft clays or loose sands. The fixed earth support method may be used for stiff clays or medium to dense sands. The design may take into consideration fixity at top of the sheet pile wall also.

**8.1.3 Factor of Safety** — In designing cantilever sheet pile walls and anchored sheet pile walls using the free earth support method, a factor of safety of 2 may be adopted on the calculated passive resistance of the soil in normal conditions and 1.5 when earthquake forces are taken into consideration. In the fixed earth support method of analysis of anchored sheet pile walls, there is hardly any danger of failure due to inadequate passive earth pressure. However, the computed depth of penetration shall be increased by 20 percent to ensure adequate fixity.

\*Code of practice for planning and design of ports and harbours : Part III Loading ( *first revision* ).

†Criteria for earthquake resistant design of structures ( *third revision* ).

**8.2 Ties** — In the design of ties, the following considerations shall be taken into account:

- a) If some vertical loading of the ties is considered likely, allowance for the resulting additional tension shall be made in design. For design purposes, the calculated tie tension shall be increased by 20 percent.
- b) Allowance shall be made in the cross-sectional area of the ties for corrosion.
- c) For taking up any slack in the ties, turn buckles shall be provided in every tie.
- d) If there is any soft soil below the ties even at a great depth, it will be consolidated under the weight of the backfill and consequently cause the ground to settle. This will cause the ties to sag and cause additional stresses. In order to eliminate these stresses, one of the following methods may be used:
  - 1) The ties may be supported with vertical piles at 6 to 8 m intervals. The piles may be driven to firm soil below the compressible layer.
  - 2) A large pipe whose inside diameter is larger than the total contemplated settlement may be installed to house the ties. The ties shall be laid on the invert of the pipe so that they will always be free inside the pipe.

**8.3 Anchorages** — Anchorages usually consist of sheet piles or concrete anchor walls which may be continuous or a series of separate units. Sheet pile anchorages are of the cantilever or balanced type. The concrete anchorage does not require walings for the distribution of load from the ties but it is necessary to excavate to the full depth which may cause difficulty when the water table is near to the ground surface. Shallow diaphragm walls may also be used as anchorages. Raking pile anchorages are sometimes used when the ground or site conditions are unsuitable for any of the above-mentioned types. The various types of anchorages are shown in Fig. 2. In the design of anchorages, the provisions of 8.3.1 to 8.3.9 shall be taken into account.

NOTE — Procedures for design of a few types of anchorages is given in Appendix D for guidance.

**8.3.1** The passive resistance of soil in front of anchorages shall be calculated without any allowance for wall friction, unless the weight of the anchorage is sufficient to balance the upward component of the resistance. The active pressure on the back of the anchorage shall be deducted to obtain the net resistance.

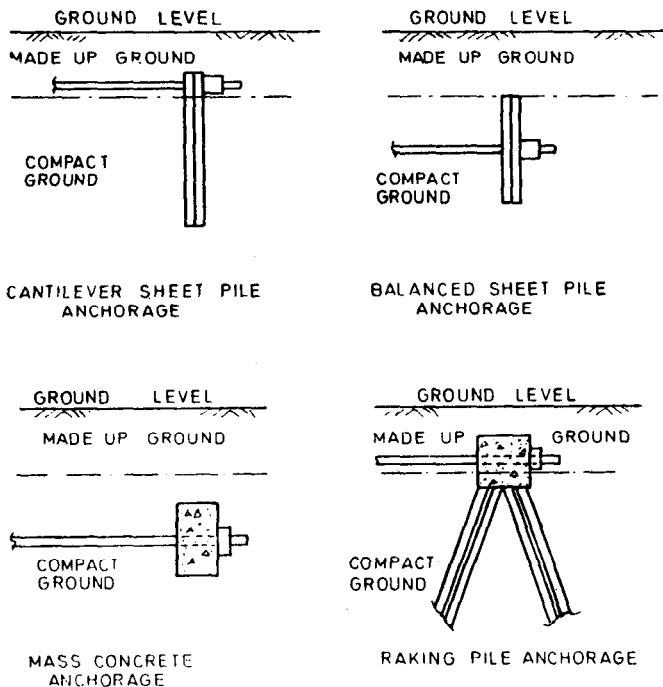

FIG. 2 TYPES OF ANCHORAGES

**8.3.2** A factor of safety of 2 shall be adopted on the passive resistance of the soil.

**8.3.3** When the depth of the anchorage  $h$  is not less than half the total depth  $h_b$  from the ground level to the bottom of the anchorage ( see Fig. 3 ), it is permissible to assume that the soil in front of it develops the resistance due to entire depth  $h_b$ . This is conditional on the anchorage being located beyond the lines  $AB$  and  $BF$ .

**8.3.4** If the anchorage consists of isolated blocks or groups of anchor piles, the passive resistance of the soil in front of each anchorage will be augmented by the shear resistance on the sides of the wedge of soil which the anchorage tends to push out. This shear resistance is dependant on the pressure of the soil against the vertical sides of the wedge and should be derived from the active pressure.

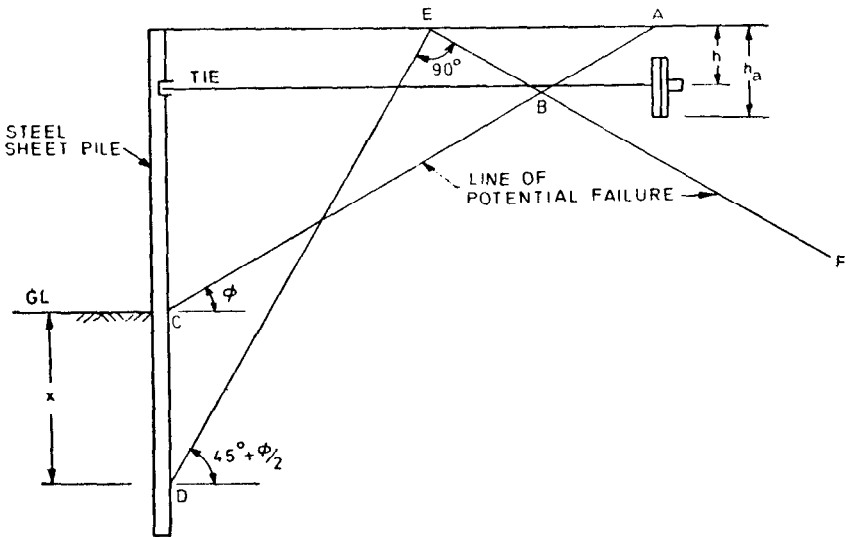

FIG. 3 LOCATION OF ANCHORAGE

**8.3.5** As an alternative to 8.3.4, the effective width of an isolated anchor block may be taken as 1.6 times of the actual width for purposes of computation of anchor resistance.

**8.3.6** The resistance of a series of isolated anchorages shall never exceed the total resistance in front of a continuous wall.

**8.3.7** The anchorage design shall be based upon the least favourable combination of conditions. This usually occurs at high water when the main wall loading is a little less than the maximum, but the anchorage resistance may be considerably less than at low water. Similarly, the application of surcharge loading just behind the wall but not immediately in front of the anchorages, constitutes a severe case which should be covered in the design.

**8.3.8** The anchorages should be situated far from the wall to avoid interference between potentially unstable soil wedges as shown in Fig. 3. If the location is such that the interference between the wedges is unavoidable, the allowable anchor pull should be reduced as given in D-5.1.

**8.3.9** In the case of raker pile anchorages some vertical load may, as a rule, be applied to the anchorage to reduce the tension in the back raker.

The design is governed by the safe carrying capacity of the pile in bearing and unlift.

#### 8.4 *Relieving Platforms*

**8.4.1 General Considerations** — The pressure on a retaining wall and bendingmoment in the sheet piling may be reduced by the provision of a reinforced concrete platform behind the piling, some distance below the ground level. In general, platform also serves as an anchorage for the sheet pile.

Where a conventional anchored retaining wall can be constructed without special difficulty, a relieving platform wall would be more costly. Walls of this kind are, therefore, used only where the construction of a conventional wall is not possible or would involve special problems, such as:

- a) When the height of the wall is so great that a conventional wall would require a large piling section than can be obtained,
- b) Where the existence of unsuitable soil prevents the use of conventional anchorages,
- c) Where there is insufficient space for ordinary ties and anchorages, and
- d) Where there are large loads from crane track or rail track requiring bearing piles to support them.

**8.4.2 Principal Characteristics** — The platform is situated at a depth, generally not less than about a quarter of the height of the wall. It should be of sufficient width to provide total or almost total shielding of the sheet piling below it from the effect of the soil above it. To achieve this, it should cover the wedge of potentially unstable soil starting from a point at or near the toe of the sheet pile. The platform is supported on bearing piles, or partly on bearing piles and partly on the sheet pile ( see Fig. 4 ). Anchorage is provided by the inclusion of raking piles, which carry part of the load of the platform and the soil above it. Backward raking piles may also be used which will increase the stability of the structure and, by acting in tension, can increase the available horizontal reaction for anchorage.

**8.4.3** The structure has to support the horizontal pressure of the soil above the platform and below the platform acting separately. A pressure diagram is drawn and analysed in the usual way to determine the penetration required below dredge level, the bending moment in the piling and the magnitude of the horizontal force applied to the platform.

**8.5 Walings** — The walings are designed to span between the ties. They may be fixed either at the back or front of the piles in the retaining wall, the latter being more economical. The former arrangement is, however, usually adopted for the sake of appearance.

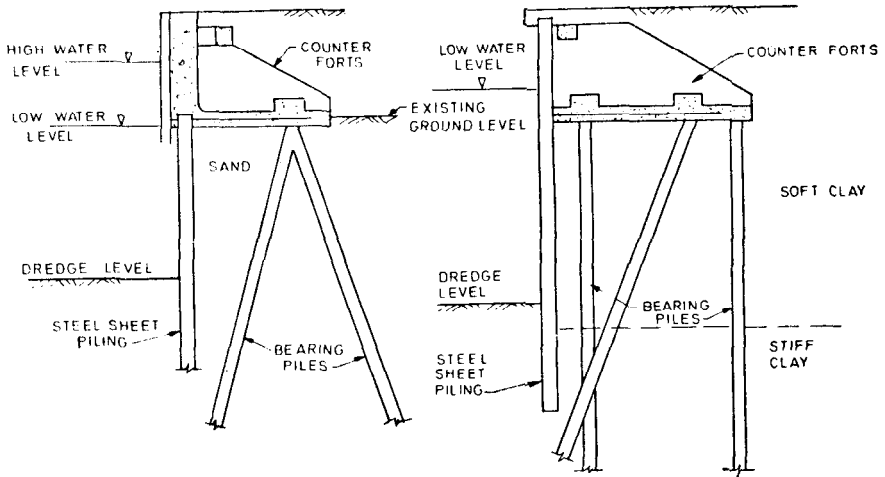

FIG. 4 RELIEVING PLATFORM

**8.6 Overall Stability** — All sheet pile wall construction shall be checked for overall stability against possible failure along a potential slip surface using the slip circle method of analysis. The stability analysis shall be made both for construction and long term conditions.

## 9. REQUIREMENTS OF PILES

### 9.1 Timber Piles

**9.1.1** In permanent structures, the pile top should be as nearer as possible to the low water level or low tide level. The pile should be suitably treated.

**9.1.2** The thickness of piles should be not less than  $L/50$  where  $L$  is the length of the pile, or 8 cm whichever is higher.

**9.1.3** The joints between the piles may be butted, lapped, V-shaped ( for thickness up to 8 cm ), tongued and grooved ( for thicker piles ).

**9.1.4** Driving shall be done with tongue leading and with the tip of the pile bevelled on the tongue. The pile being driven thus gets pressed against the already driven piles.

**9.1.5** Where driving is hard, a cutting shoe of steel plate may be provided. The top of the pile should be protected by steel bands. The cutting edge may be sloped 1 to 6 to assist in keeping the pile in close contact with the sheeting already driven.

## 9.2 Reinforced or Prestressed Concrete Piles

9.2.1 The reinforced concrete shall conform to IS : 456-1978\* and prestressed concrete to IS : 1343-1980†.

9.2.2 The thickness of the piles shall be not less than 15 cm.

9.2.3 Adequate reinforcement shall be provided to take care of handling and driving stresses.

9.2.4 The piles may have trapezoidal, triangular or semi-circular grooves. The width of grooves may be one-third the thickness of the pile but not larger than 10 cm. The depth of grooves may not be more than 5 cm. The grooves shall run continuously to the lower end of the pile on the leading side. On the opposite side, the pile shall have a tongue of not less than 1.5 cm length which will fit in the groove while driving ( see Fig. 5 ).

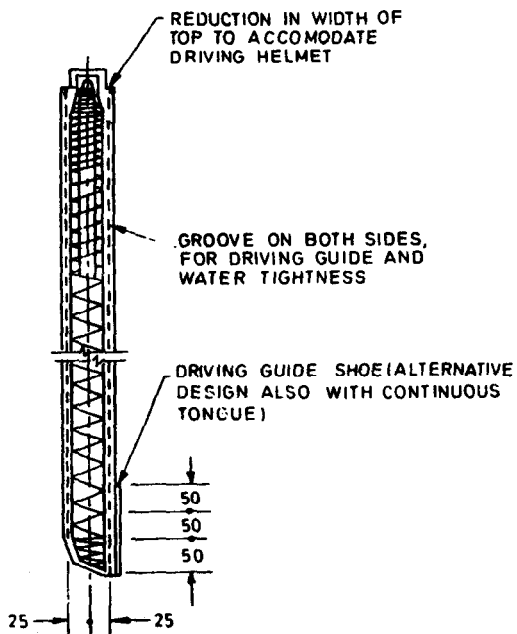

FIG. 5 SALIENT FEATURES OF REINFORCED OR PRESTRESSED CONCRETE SHEET PILES

\*Code of practice for plain and reinforced concrete ( *third revision* ).

†Code of practice for prestressed concrete ( *first revision* ).

**9.2.5** The pile may have a steel shoe if hard driving is anticipated.

**9.2.6** The point of the pile is bevelled to about 2 : 1 on the leading side so that the pile stresses against the already driven sheeting.

**9.2.7** When the piles have been driven, the concrete shall be stripped from the pile heads and the reinforcement exposed for depth to permit it to be bonded into the pile capping as specified in IS : 2911 ( Part I/ Sec 3 )-1979\*.

**9.2.8** Where a pile is to have another length cast on it, the reinforcement should be lapped for a distance of at least 40 diameters of the longitudinal bars. Alternatively, the joints in the longitudinal bars may be butt-welded to develop full strength. The extension should be truly in line with the remainder of pile.

### **9.3 Steel Sheet Piles**

**9.3.1** Steel sheet piles are of various types such as Z-section, U-section and arch-web type. The theoretical section modulus developed by various types of piles depends upon the friction that develops in the clutching. In Z-section piles clutches occur on the edges while in U-section piles, they occur in the mid-section of overall wall depth. Arch-web and Z-section piles are used to resist larger bending moments.

**9.3.2** Steel piling used for permanent work shall be provided with a protective coating before driving. The coating shall be renewed on the exposed part of the piling periodically.

**9.3.3** The piles may be spliced by butt welding or spliced with bolted, riveted or welded cover plates.

**9.3.4** Bent corner piles, closure and junction piles may be prepared either by welding or by riveting.

**9.3.5** The sheet piles may preferably be driven by double acting hammer. Single acting hammer is liable to damage the tip of the pile and hence should be avoided, if possible. In granular soils, vibrosinkers are very effective.

**9.4 Weepholes** — Weepholes may be provided as found necessary above MLW.

**9.5 Backfill Material** — The filling material shall be hard, granular and free-draining.

---

\*Code of practice for design and construction of pile foundations : Part I Concrete piles, Section 3 Driven precast concrete piles.

## APPENDIX A

( Clause 8.1.1 )

### DESIGN OF CANTILEVER SHEET PILE WALL

#### A-1. PROCEDURE

**A-1.1** The required depth of penetration is determined by a trial and error procedure as explained in **A-1.2** to **A-1.8** with reference to a simple case shown in Fig. 6.

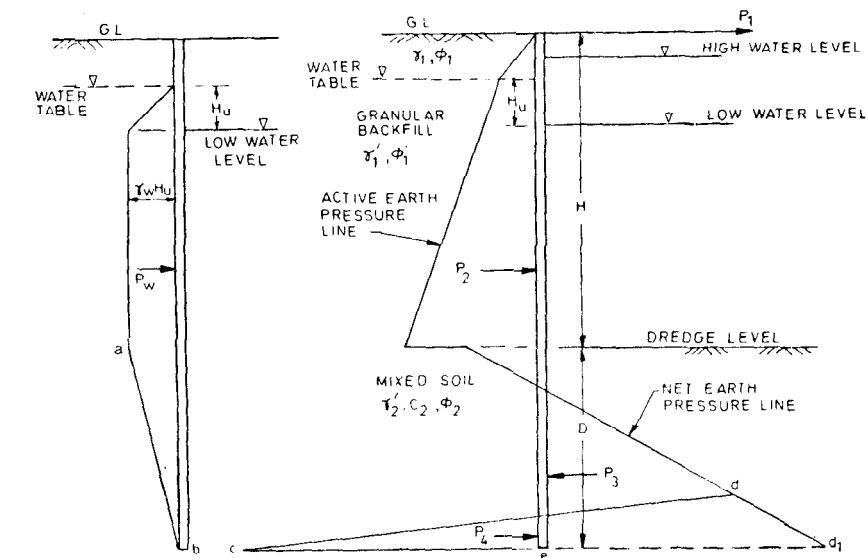

6A Distribution of Unbalanced Water Pressure

6B Distribution of Earth Pressure

FIG. 6 FORCES ACTING ON A CANTILEVER SHEET PILE WALL

**A-1.2** The forces acting on a unit length of the wall for a trial depth,  $D$  are:

- Mooring pull,  $P_1$ ;
- Total unbalanced water pressure,  $P_w$ ;
- Total earth pressure on the side of the backfill,  $P_2$ ;

- d) Total net resisting force due to soil in front of the wall below the dredge level,  $P_3$ ; and
- e) Total net resisting force due to soil near the toe of the wall acting on the side of the backfill,  $P_4$ .

**A-1.3** The intensity of net resisting pressure at any depth shall be taken as the difference between the mobilised passive pressure subject to the provision in **A-1.4**, and the active pressure on the other side of the wall at the same depth.

**A-1.4** The mobilised passive pressure at any depth equals the passive pressure at that depth divided by the factor of safety equal to 2.

**A-1.5** The ordinate 'ce' of the earth pressure diagram at the level of the toe on the side of the backfill equals the intensity of the net resisting pressure at that depth according to **A-1.3**.

**A-1.6** The inclination of the straight line 'cd' shall be so adjusted as to ensure equilibrium of all the forces in the horizontal direction.

**A-1.7** The trial depth of embedment,  $D$  shall be adjusted until the resultant moment of all the forces about toe on the sheet pile wall equals zero.

**A-1.8** The pile section shall be designed for the maximum bending moment caused by the various forces.

## APPENDIX B

( Clause 8.1.2 )

### DESIGN OF ANCHORED SHEET PILE WALLS BY FREE-EARTH SUPPORT METHOD

#### B-1. PROCEDURE

**B-1.1** The forces acting on a unit length of an anchored sheet pile wall under simple soil conditions are represented in Fig. 7. They are the following:

- a) Mooring pull,  $P_1$ ;
- b) Anchor pull ( tension in tie ),  $A_p$ ;
- c) Total unbalanced water pressure,  $P_w$ ;
- d) Total earth pressure on the side of the backfill,  $P_2$ ; and
- e) Total net resisting force due to soil in front of the wall below the dredge level,  $P_3$ .

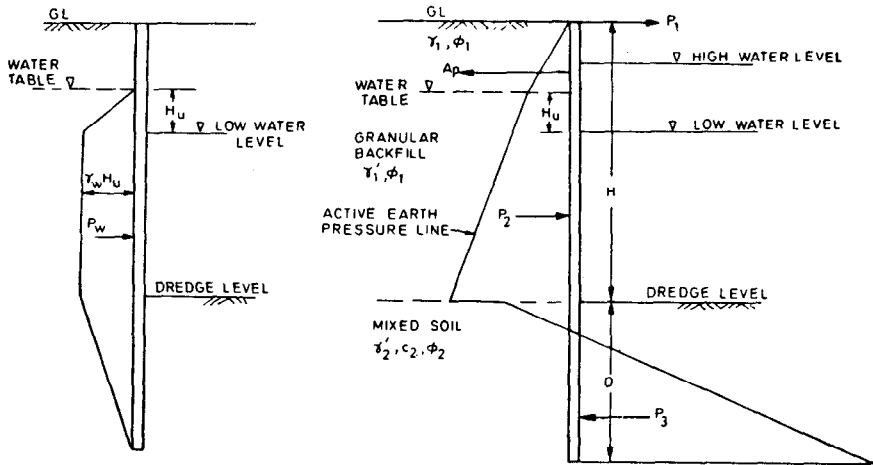

7A Distribution of Unbalanced Water Pressure

7B Distribution of Earth Pressure

FIG. 7 FREE-EARTH SUPPORT METHOD FOR DESIGN OF ANCHORED SHEET PILE WALLS

**B-1.2** The intensity of net resisting force due to soil and its resultant  $P_3$  shall be determined as per clause A-1.3 and A-1.4.

**B-1.3** The depth of penetration  $D$ , shall be such that the resultant moment about the line of action of the anchor pull  $A_p$ , is equal to zero.

**B-1.4** The magnitude of the anchor pull  $A_p$ , is determined by considering the equilibrium in the horizontal direction of all the forces acting on the sheet pile wall.

**B-1.5** The maximum bending moment in the sheet pile wall shall be computed for all the forces indicated in B-1.1 for determining the pile section.

**B-1.6** The anchor rods shall be designed for a tension equal to that determined in accordance with B-1.4, increased by 20 percent [ see 8.2 (a) ].



**TABLE 1 DEPTH OF POINT OF INFLEXION BELOW  
THE DREDGE LEVEL**

( Clause C-1.2 )

Angle of internal friction, $\phi$	20°	30°	40°
Depth of point of inflexion, $x$	0.25H	0.08H	0.007H

**C-1.3** The portion of the pile 'ac' above the point of inflexion, 'c' shall be treated as a beam, simply supported at points 'b' and 'c' and the reactions  $A_p$  and  $R_0$  at 'b' and 'c' respectively are determined using statics.

**C-1.4** The length, 'cd' of the pile below the point of inflexion 'c' should be treated as a beam simply supported at points, 'c' and 'd' with known reaction  $R'$  ( equal in magnitude and opposite in direction to  $R$  ) and loaded with distributed net resisting soil pressure as shown in Fig. 8. The length  $D'$  of the pile consistent with static equilibrium is determined.

**C-1.5** The depth of embedment (  $D' + x$  ) thus obtained is increased by 20 percent to ensure adequate fixity at the toe ( see 8.1.3 ). Hence the required depth of penetration,  $D$  is given by,

$$D = 1.2 ( D' + x )$$

**C-1.6** The maximum bending moment in the pile shall be computed for all the forces ( see C-1.1 ) for designing the pile section.

**C-1.7** The anchor pull  $A_p$  computed in C-1.3 shall be increased by 20 percent for purposes of design of anchor rods.

## APPENDIX D

( Note below Clauses 8.3 and 8.3.8 )

### DESIGN OF ANCHORAGES

#### D-1. DESIGN OF ANCHORING WALL

**D-1.1** The anchoring wall is designed to resist the tension in the tie and the active earth pressure of the soil behind the anchoring wall owing to the passive earth pressure of the soil ( Fig. 9 ). The wall's height and installation depth shall be calculated as below:

$$F_s = \frac{P_p}{A_p + P_A}$$

where

$F_s$  = factor of safety ( equal to 2 );

$P_p$  = passive earth pressure acting on the anchoring wall,  
 $A_p$  = reaction force at tie level, and  
 $P_A$  = active earth pressure acting on the anchoring wall.

NOTE 1 — The surcharge should be taken into consideration in calculating the active earth pressure and be disregarded in case of passive earth pressure.

NOTE 2 — The angle of earth friction on the wall,  $\delta$  is  $15^\circ$  for the active earth pressure and  $0^\circ$  for the passive earth pressure.

NOTE 3 — In case the active rupture surface of the sheet pile wall intersects the passive rupture surface of the anchoring wall beneath the ground, the portion of the passive earth pressure above the point where the two surfaces intersect should be subtracted from the value of  $P_p$  in the equation because of bearing no resistance.

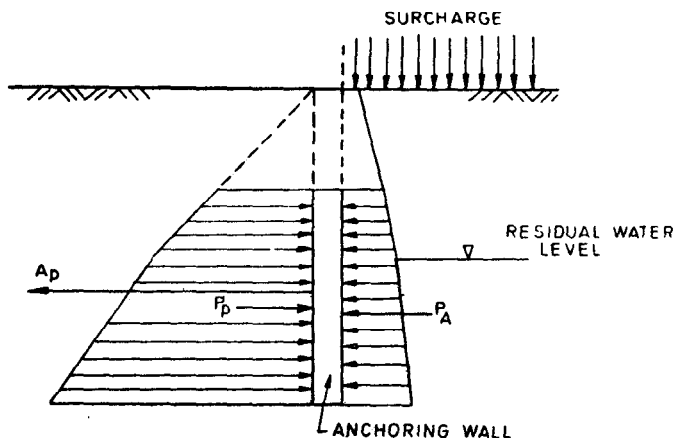

FIG. 9 EXTERNAL FORCES ACTING ON ANCHORING WALL

**D-1.2** The maximum bending moment of the anchoring wall may be computed, assuming the earth pressure as uniform load, and the anchoring walls as continuous slab in the horizontal direction and cantilever in the vertical directions as given below:

$$M_h = \frac{Tl}{12}$$

$$M_v = \frac{Th}{8l}$$

where

$M_h$  = maximum bending moment in horizontal direction,

- $T$  = tension in tie,
- $l$  = interval of tie,
- $M_v$  = maximum bending moment in vertical direction, and
- $h$  = height of anchoring wall.

The location of anchoring wall is shown in Fig. 10.

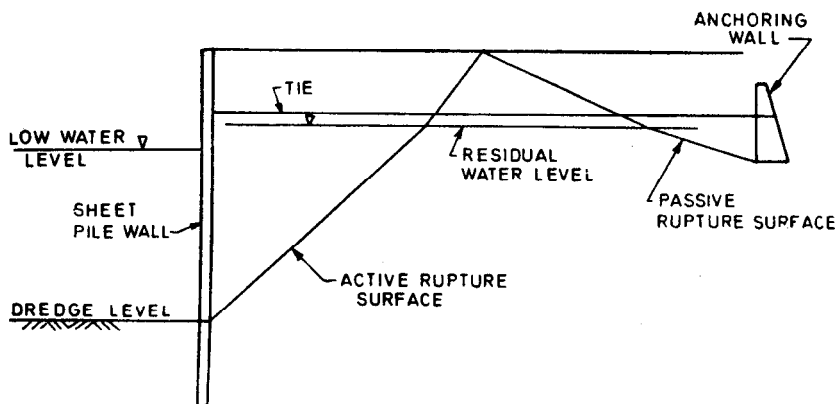

FIG. 10 LOCATION OF ANCHORING WALL

## D-2. DESIGN OF ANCHORING PILE

**D-2.1** The maximum bending moment of an embedded anchoring pile is calculated by the following equation:

$$M_{\max} = \frac{T}{\beta} \exp(-\pi/4) \sin \pi/4 = 0.322 T/\beta$$

where

$T$  = tension in tie,

$$\beta = \sqrt[4]{\frac{B n_h}{4 E I}},$$

$B$  = width of anchoring pile,

$n_h$  = coefficient of lateral reaction of soil,

$E$  = Young's modulus of the material of the anchoring pile, and

$I$  = moment of inertia of anchoring pile.

**D-2.2** The embedded length of anchoring pile shall not be less than  $l_m$  calculated as below:

$$l_m = \frac{\pi}{\beta}$$

**D-2.3** The bending moment in anchoring pile and location of anchoring pile are shown in Fig. 11 and 12.

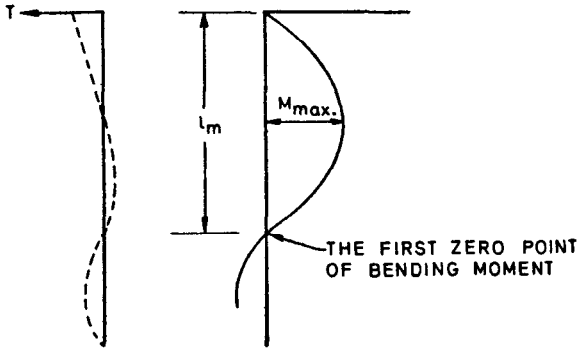

FIG. 11 BENDING MOMENT IN ANCHORING PILE

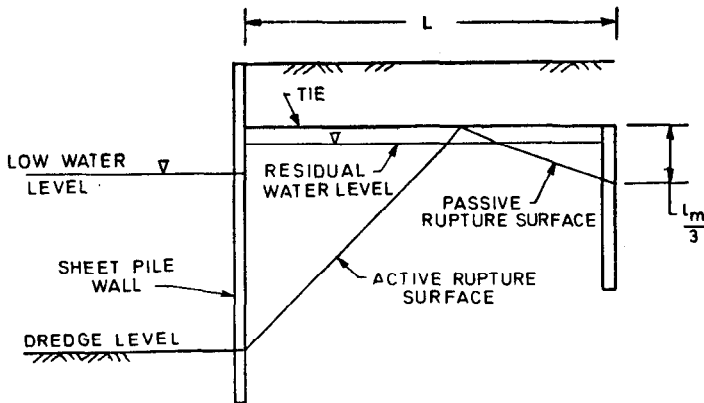

FIG. 12 LOCATION OF ANCHORING PILE

**D-2.4** The displacement of the anchoring pile head,  $\delta$  is calculated by the following equation:

$$\delta = \frac{T}{2 E I \beta^3}$$

**D-2.5** The location of the anchoring pile shall be such that the passive rupture surface, originating from the point  $l_{m/3}$  below the tie level, intersects the active rupture surface of the sheet pile wall above the tie level.

### D-3. DESIGN OF ANCHORING SHEET PILE WALL

**D-3.1** In case the penetration depth of the anchoring sheet pile below the tie level is not less than  $\pi/\beta$  ( see **D-2.1** and **D-2.2** ), the required section modulus of the sheet piling is determined by the same design method used for the anchoring pile.

**D-3.2** In case the penetration depth of the anchoring sheet pile below the tie level is shorter than  $\pi/\beta$ , the required section of sheet piling is determined by the same design method used for the anchoring wall.

### D-4. DESIGN OF ANCHORING COMBINED BATTER PILES

**D-4.1** The axial force of the anchoring combined batter piles may be calculated by the following equation:

$$P_1 = \frac{V \sin \theta_2 + H \cos \theta_2}{\sin (\theta_1 + \theta_2)}$$

$$P_2 = \frac{V \sin \theta_1 - H \cos \theta_1}{\sin (\theta_1 + \theta_2)}$$

where

$P_1, P_2$  = thrusting force on individual pile ( negative value indicates pulling force ),

$\theta_1, \theta_2$  = angle of inclination of individual pile,

$V$  = vertical force for combined batter piles, and

$H$  = horizontal force for combined batter piles.

**D-4.2** The system of anchoring combined batter piles and the location of anchoring combined batter piles are shown in Fig. 13 and 14.

### D-5. REDUCTION IN ANCHOR PULL

**D-5.1** Reduced anchor pull for interference of potentially unstable soil wedges is given by the following equation:

$$A_p = [ ( P_p - P_A ) - ( P'_p - P'_A ) ] \frac{L}{F_s}$$

where

$A_p$  = allowable anchor pull,

$P_p, P'_p$  = passive earth pressure,

$P_A, P'_A$  = active earth pressure,

$L$  = length of deadman, and

$F_s$  = factor of safety.

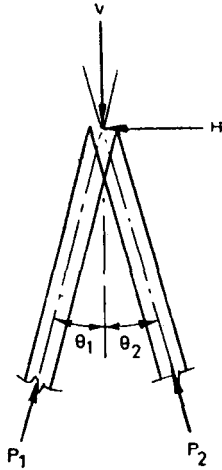

FIG. 13 ANCHORING COMBINED BATTER PILES

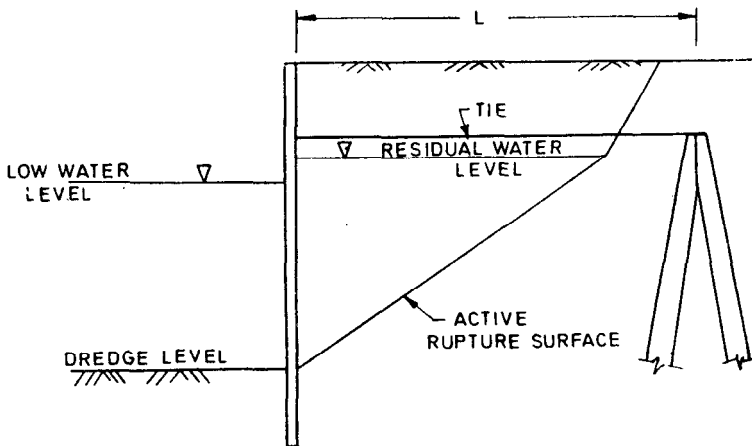

FIG. 14 LOCATION OF ANCHORING COMBINED BATTER PILES

# BUREAU OF INDIAN STANDARDS

## Headquarters:

Manak Bhavan, 9 Bahadur Shah Zafar Marg, NEW DELHI 110002

Telephones: 323 0131, 323 3375, 323 9402

Fax : 91 11 3234062, 91 11 3239399, 91 11 3239382

Telegrams : Manaksanstha  
(Common to all Offices)

## Central Laboratory:

Plot No. 20/9, Site IV, Sahibabad Industrial Area, SAHIBABAD 201010

Telephone  
8-77 00 32

## Regional Offices:

Central : Manak Bhavan, 9 Bahadur Shah Zafar Marg, NEW DELHI 110002	323 76 17
*Eastern : 1/14 CIT Scheme VII M, V.I.P. Road, Manikola, CALCUTTA 700054	337 86 62
Northern : SCO 335-336, Sector 34-A, CHANDIGARH 160022	60 38 43
Southern : C.I.T. Campus, IV Cross Road, CHENNAI 600113	235 23 15
†Western : Manakalaya, E9 Behind Marol Telephone Exchange, Andheri (East), MUMBAI 400093	832 92 95

## Branch Offices:

'Pushpak', Nurmohamed Shaikh Marg, Khanpur, AHMEDABAD 380001	550 13 48
‡Peenya Industrial Area, 1st Stage, Bangalore - Tumkur Road, BANGALORE 560058	839 49 55
Gangotri Complex, 5th Floor, Bhadbhada Road, T. T. Nagar, BHOPAL 462003	55 40 21
Plot No. 62-63, Unit VI, Ganga Nagar, BHUBANESHWAR 751001	40 36 27
Kalaikathir Buildings, 670 Avinashi Road, COIMBATORE 641037	21 01 41
Plot No. 43, Sector 16 A, Mathura Road, FARIDABAD 121001	8-28 88 01
Savitri Complex, 116 G. T. Road, GHAZIABAD 201001	8-71 19 96
53/5 Ward No. 29, R. G. Barua Road, 5th By-lane, GUWAHATI 781003	54 11 37
5-8-58C, L. N. Gupta Marg, Nampally Station Road, HYDERABAD 500001	20 10 83
E-52, Chitaranjan Marg, C-Scheme, JAIPUR 302001	37 29 25
117/418 B, Sarvodaya Nagar, KANPUR 208005	21 68 76
Seth Bhawan, 2nd Floor, Behind Leela Cinema, Naval Kishore Road, LUCKNOW 226001	23 89 23
Patliputra Industrial Estate, PATNA 800013	26 23 05
T. C. No. 14/1421, University P. O. Palayam, THIRUVANANTHAPURAM 695034	6 21 17
NIT Building, Second Floor, Gokulpat Market, NAGPUR 440010	52 51 71
Institution of Engineers ( India ) Building, 1332 Shivaji Nagar, PUNE 411005	32 36 35

\*Sales Office is at 5 Chowringhee Approach, P. O. Princep Street,  
CALCUTTA 700072 27 10 85

†Sales Office is at Novelty Chambers, Grant Road, MUMBAI 400007 309 65 28

‡Sales Office is at 'F' Block, Unity Building, Narashimaraja Square,  
BANGALORE 560002 222 39 71